

Quail Call

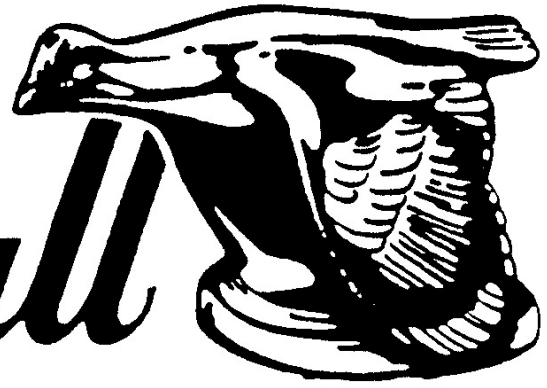

March



Sun	Mon	Tue	Wed	Thu	Fri	Sat
		1	2	3	4	5 OCEAN BEACH KITE PARADE
6	7			10	11 MEETING 7PM SAN CARLOS REC. CENTER	12 TECH SEMINAR OR LADIES FASHION TEA
13 Daylight Saving Time Starts	14			17 Happy St. Patrick's Day	18	19
20	21			24	25	26 ORANGE COUNTY OVERNIGHT
27 ORANGE COUNTY PANCAKE BREAKFAST	28 BOARD MEETING 7pm @ Dodge's	29		31	1	2 FLOWER FIELD TOUR
3	4	5	6	7 LEAVE FOR LAUGHLIN	8 MEETING 7PM SAN CARLOS REC. CENTER	9 2011



QUAIL CALL

EDITOR

Valarie Basham
9271 Huntington Ave.
San Diego, Ca. 92123-3124
(858) 278-6317

Published monthly by MARC/MAFCA of San Diego.
All articles submitted for publication should reach the editor
before the 25th of each month. All articles become the property
of MARC/ MAFCA of San Diego and are subject to corrections
or revisions. Permission granted to reprint articles.

E-mail: dcmomof12@aol.com

WEBSITE

www.sdmodelaclub.com

2011 BOARD OF DIRECTORS AND COMMITTEE CHAIRMEN

BOARD OF DIRECTORS

DIRECTOR	Bud Swartwood	(619) 579-6726
ASST. DIR.	Paul Winchester	(619) 669-0737
SECRETARY	Carol Weckman	(858) 279-0596
TREASURER	Roxy Faust	(619) 297-1424
TECHNICAL	Arlyn Bieber	(858) 530-2336
TOURS	Roger Ball	(619) 465-4110
PAST DIR.	Dave Sohr	(619) 440-0374

Board Meetings are held quarterly: see *Quail Call* for dates and location. All member are welcome to attend, just let the host or hostess know you are coming.

COMMITTEE CHAIRMEN

Membership	Roger Phillips	(858) 454-5070
Fashions	JoBeth Stelzer	(619) 698-3256
Historian	Patty Winchester	(619) 669-0737
Refreshments	Lisa Kelly	(619) 442-8332
Cor. Secretary	Diane Seeman	(619) 749-5608
Property	Reen Kotas	(858) 278-8178
Ways & Means	Rich Phillips	(619) 670-7843
Rec. Rep.	JudyJo Beardslee	(619) 465-9513
Defender,	Ray Beardslee	(619) 465-9513
Mail-box	Ray Beardslee	(619) 465-9513

CLUB MAILING ADDRESS: P.O. BOX 19805 SAN DIEGO, CA. 92159

BUSINESS MEETING HELD THE 2ND FRIDAY OF EACH MONTH AT 7:00 PM

**San Carlos Recreation Center
6445 Lake Badin Ave.**

San Diego, Ca. (619) 527-3443

The San Diego Model A Club was first founded in 1957 by a few dedicated Model A owners. Our purpose is to help preserve the Model A, which was in production by the Ford Motor Company from 1928-1931. Ownership of a Model A is not a requirement for membership in the club. Membership dues are \$30.00 per calendar year. Membership in one of the National Clubs is mandatory (either MARC or MAFCA) and the responsibility of each member. Contact information to join a National Club is listed below:



Model A Restorers Club

6721 Merriman Road,
Garden Grove Michigan 48135
(734) 427-9050

E-mail: modelarestorers@sbcglobal.net

Website: www.modelaford.org

Dues are \$38.00 per calendar year.

Model A Ford Club of America

250 S. Cypress Street
La Habra, Ca. 90631-5515
(562) 697-2712

E-mail: info@mafca.com

Website: www.mafca.com

Dues are \$40.00 per calendar year.

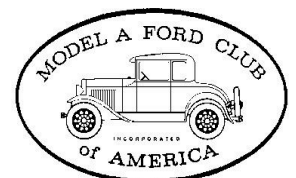

DIRECTOR'S REPORT: Bud Swartwood

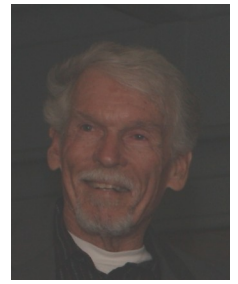

This is generally a fun time of the year as we look beyond the rainy, cool weather and plan ahead for opportunities to drive our Model A's and get together with friends having a similar interest. The first Technical Seminar for this year is scheduled for March 12th. This is a great time to see how remarkable the Model A engineering really is. It could be a good time to check your car or ask any number of Club Members for their suggestions to make your car a reliable part of an up coming Tour or participant in a Parade or car display. The Fashion Tea is also planned for the 12th. Model A era fashions are a unique way to appreciate the Model A hobby. JoBeth Stelzer can offer assistance and answer questions you may have.

The Orange County Model A Club is once again sponsoring the **Annual Pancake Breakfast on Sunday, March 27, 2011**. If you want to attend and have not yet made your arrangements please do so. You will have fun and be able to view a large number of Model A's. You will find specific information in the Quail Call.

The **Annual Laughlin Tour is scheduled for April 7 - 9**. This is a popular Club event with many members who attend each year. Contact Valarie Basham if you are interested or just need more information. Unfortunately the Club monthly meeting is April 8, the same weekend.

The Model A Museum is coming closer to reality. Check out the Gilmore Car Museum located at Hickory Corners, Michigan. This Museum is sponsored by the Model A Ford Foundation, Inc, the Model A Ford Club of America and the Model A Restorers Club. A unified effort to present " A Stroll Through The Model A Years".

Not getting the Google Group e-mail or not sure if you are missing the last note sent?? Let me know. I can include your e-mail address individually as needed. Receiving your copy of the Quail Call each month via e-mail is a great way to save the Club money, reducing both postage & printing costs. Let Valarie Basham know if this would work for you.

The next regular monthly Club Meeting is scheduled for March 11. The quarterly Board Meeting will be held March 28th. Please let me know if you have an agenda item for either of these Club meetings.

BIG THREE SWAP MEET

Editorial Note: At least one day of the Big Three Swap meet you can expect drizzle or sprinkles, this year did not disappoint, here is one members personal account: Thanks Dave for sharing you experience:



Upon leaving my nice warm house to fight the rain, washed out roads, and the river going thru the stadium parking lot, I got to my space. Fearing the wettest and most miserable day I decided to stick it out. Soon the only member Gene Amy stopped by with the windshield wiper on high, rain pouring down he rolled down the steam covered window and looked at me with that "Are You Freaking Crazy ?" look. After a few words and time running out he headed out. But In our conversation I explained that I heard that last year Sat. was pouring down and the vendors did real well. I put on the rain boots and coat and set up to sell. Next I heard the fire marshal is shutting the meet down, evacuating all vendors south of trolley And the rain continued. I put up a couple tarps spread out my junk and all hell broke lose. I was hit with a massive amount of shoppers (vendors with nothing to do). Course I gave everyone super deals, had a lot of return customers and stayed busy all day. Nothing better than seeing 40lbs. of iron dragged away as I stash another Grand. I'll head home in the dark and Load up more junk. See Ya Sunday!!! Dave Sohr

Minutes of the San Diego Model A Club General Meeting February 11, 2011

The meeting called to order by Bud Swartwood at 7:02, followed by pledge of allegiance.

Minutes of January meeting passed as printed in the Quail Call.

Parades: Paul Winchester reported first parades will not happen til April. Gave a rundown of parades and displays for April, May and June.

Tours: Roger Ball spoke on Campo tour this Sat. Upcoming tours include Orange Co. pancake breakfast, Laughlin and possible flower fields picture with Palomar club. Still open for suggestions.

MARC meet: will be meeting at Big Three swap meet. Gary spoke on meet, registration in latest MARC News , expecting big turnout.

Treasurer: Roxy read current balances. Motion passed to pay current bills.

Technical: Arlyn Bieber announced that Revision 3 of Restoration Guidelines and judging standards will be out shortly. He also read article from "Ford News" of 1931 record set by model A driving for 50,091 miles without stopping.

Fashion: Nayola Beiber needs two people to help tabulate fashion scores. Jo Beth brought in a collection of boys cloths. She also reminded everyone of Ladies tea on March 12th. Judy Jo brought in a large collection of era clothes for those interested.

Membership: 70 members in attendance 3 new members, 2 returning and some quests. Eleanor gave out membership awards for those who missed the banquet.

Quail Call: Valarie Basham gave out 2011 rosters, first free, additional \$1.00. Also sent around clipboard.

Membership award: Congratulations to Ron Polk.

Ways & Means: Another great group of prizes plus A box of Valentine's candy for door prize.

Old business: Fred Meyers told the newer members about the former Model A Fun Meet and donated his past trophies to the club.

New Business: Paul Abbott requested the club make a \$50.00 donation to Laughlin Meet. Motion passed.

Hard Luck Trophy: Ron Peterson ducked out early so missed out again on getting trophy.

Meeting adjourned at 8:30pm

Respectfully submitted by Sue Winnett, acting recording secretary.



TOURS: Roger Ball



Great weekend weather greeted the Club's first tour for 2011 on Saturday, February 12. Fourteen Model A's gathered at the Target parking lot in El Cajon, departed at 9:00 am and made their way to Hwy. 94 where two more A's joined the tour. We headed east, winding through the mountains on the way to Campo and our first stop, at the Pacific Southwest Railway Museum. Most of the participants then took the 12 mile round trip train ride to the International Border and back to the museum display yard. After touring through the historic rail cars and steam engines, we all sat down and enjoyed a picnic lunch.

Our next stop was at the Motor Transport (Truck) Museum. Brian, the museum docent, gave us a quick presentation on local history, then led us on a tour of the vehicles on display and the restoration projects all housed inside the historic feldspar mill building. Following the Truck Museum visit we headed north to Buckman Springs, then followed Old Hwy. 80 west on our return trip. This was a great excursion to start the year with outstanding weather, great scenery and excellent company. Mileage goes to: Ray Beardslee, Bill and Sue Hansen, Bud & Judy Swartwood, David Fanning, Roy Jensen, Gene Amy, Ron and Joyce Peterson, Tom & Jacque Ace, Ray & Barbara Miller, Ladd Graham, Ron Polk, Reen Kotas, Valarie Basham, Bill Corson, Richard Potts, and Roger & Lorrie Ball.



UPCOMING TOURS:

The next tour event will be in conjunction with the **Orange County Model A Ford Club's annual Pancake Breakfast**. The Breakfast is on Sunday, March 27. Those who are traveling to Orange on Saturday, 3/26 for an overnight stay are encouraged to join with the Palomar A's for a group tour led by John Frazee which will avoid travel on the Interstate Highways. We will meet the Palomar A's at 9:00 am at the Park-And-Ride lot located at the I-15 interchange with Hwy 76. Those who would like to join on this tour should meet at Keith's Restaurant located at 9449 Kearny Villa Rd, just west of I-15 and north of Miramar Rd. with a planned departure at 7:30 am. A sign up list will be circulated at the club business meeting on March 11. For overnight lodging, contact: Best Western Orange Plaza, 1302 W. Chapman Ave., Orange, CA 92868, (714) 633-7720.

The following weekend will feature a colorful tour to the famous **Carlsbad Flower Fields on Saturday, April 2**. The flowers will be in full bloom for our visit! We will join the Palomar A's again for this event and John Frazee has arranged for free entry for everyone traveling in a Model A (normally \$10 per adult). We will have a special area to park the cars and will be able to snap some great photos during our visit. April 2nd is the first day of the Arts and Crafts Fair, one of the Flower Fields' most popular special events. We will have lunch at one of the nearby restaurants and are exploring a possible visit to the nearby Craftsman Museum in the afternoon. The tentative plan is to meet the Palomar A's at 10:00 am at the TGI Friday's parking lot (perhaps better known as the old Pea Soup Anderson's) located at Palomar Airport Rd. & Paseo Del Norte in Carlsbad. We will meet at the Toys-R-Us parking lot located at 1240 W. Morena Blvd. with a planned departure of 8:30 am and a planned coastal tour on the way to Carlsbad. We hope you can join us!

The annual **Laughlin Meet** hosted by the Pomona Valley Model A Club is **April 7-10**. You haven't been before, talk with some one who has, they always have a great time. You must make your own meet reservations with the Pomona Valley Club see Valarie Basham 858-278-6317 for a form and your own hotel reservations at the Riverside Hotel or the hotel of your choice.

PARADES: Paul Winchester

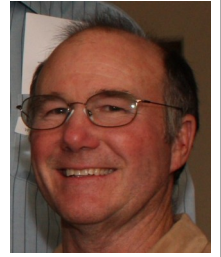

We had no Parades in February, so I spent my weekends repairing my 1928 steering box so I would be able to go to the upcoming events this year. I also ordered a new windshield wiper motor, the one on the car stopped working on the way home from the Idyllwild tour last year. As I look out the window today, I think I need to actually install the windshield wipers, now.

We have been invited to attend the Ocean Beach Kite Parade in Ocean Beach on Saturday March 5th. I would like to meet at Toys R Us on Morena Blvd. leaving at 11:30am for O.B. This will give us time to walk around and have lunch before the 2:00pm parade starts. This parade is informal (we may be the only ones there) and it goes on rain or shine. It is primary for the kids who have spent the morning building kites, they run down the street behind us to the ocean to fly them. It's a fun day.

Upcoming in April, Saturday April 16th, the Lakeside Parade and Linda Vista Parade, I'm sure we have enough cars to do both at the same time. More about that later.

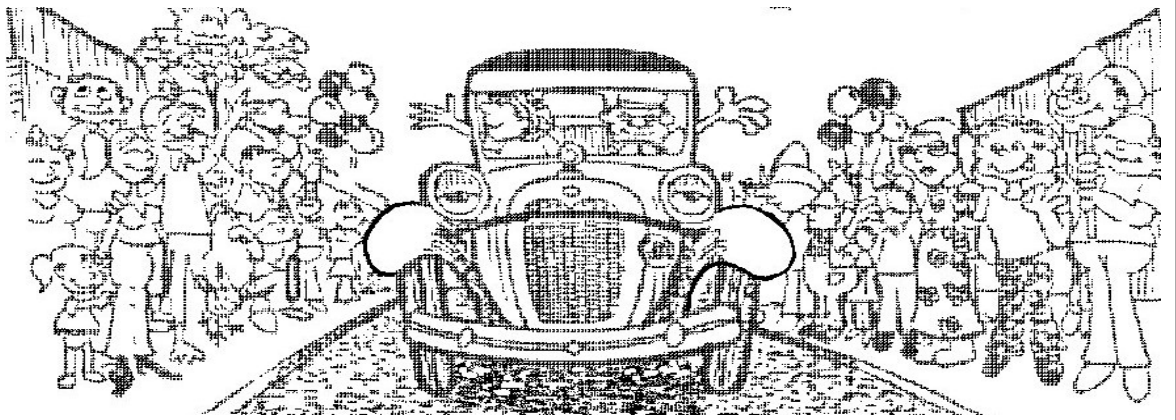

TECHNICAL SEMINAR & FASHION TEA WEEKEND

SATURDAY MARCH 12, 2011

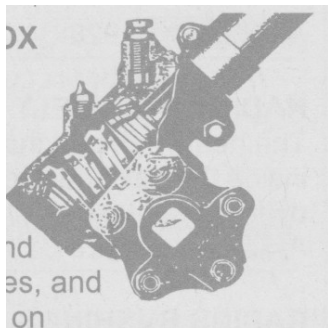

Plan to attend the MEN'S technical seminar, **RESTORING THE MODEL A TWO TOOTH STEERING BOX** on Saturday, March 12, 9:00am, **HANSEN FORD GARAGE**, 14755 Mussey Grade Road, Ramona.

AND

For the **LADIES**, **TEA TIME**, 11am cost of \$5.00 per person at the home of Lisa Kelly, **4633 Hillview Dr. La Mesa**. Please RSVP to JoBeth @ 619-698-3256. If you have any era items that you would be willing to lend out to other club members. Please bring them along, so we may put together some winning outfits for the MARC National Meet. To be held right here in San Diego in June at the Town &



TECHNICAL TIPS.... Arlyn Bieber

TECHNICAL SEMINARS AT 2011 MARC NATIONAL MEET

Send in your Registration Form to register for the 2011 MARC Meet to be held here in San Diego!!! Obtain this form from the January-February issue of the Model "A" News magazine **OR** the Pacific A's web site, 2011marcmeet.com. **For those of you who haven't joined MARC, do so on the Registration Form (New MARC Membership (domestic) - \$38.00)**. Do sign-up to attend many, many different types of events! You will learn so much and have a great time too.



Don't miss attending the technical seminars as some of the most knowledgeable people in our Model A hobby have volunteered to share their knowledge with us. Printed in the February Quail Call is a partial list of the seminars and the following is a description of the other technical seminars. ***Hope you will plan to attend all seminars.***

Judging the Canadian Model A by Carl Becker and Steve Schmauch.

Carl and Steve will give a brief history on Ford of Canada, how it was started and the world markets it supplied. The differences between the U.S. production and the Canadian Model As will be discussed. For example, Canadian As used square socket Robertson screws instead of the slotted screws. This is a rare opportunity to learn about the As north of our border.

Side Curtains (MARC seminar 1) by Bill Sturm.

Bill is a noted authority on Model upholstery and has upholstered many high point blue ribbons Model As. He will be discussing the construction of the Model A side curtains as well as upholstery material that is available today.

Windshield Wipers (MARC seminar 2) by Mick Isbell.

Mick will be discussing the history and manufacturers of the electric windshield wipers used on the Model As. He will also discuss how to maintain and repair the electric wipers as well as what repair parts are currently available. If your Model A has an electric wiper, this is a must attend seminar.

Seminar – The New Engine Block by Terry Burtz.

Terry has worked for several years on casting a new Model A engine block that looks just like the original engine. This new engine will have all new parts and will develop about 150 HP. The current schedule calls for a completed engine by June so hopefully the attendees of this seminar will be able to see the finished engine and hear it run.

Seminar - Engine Rebuilding by H&H Antique Engine Rebuilding

H&H has been rebuilding Model A engines for years. They will be talking about the modifications they make internally to the engines and the special parts they manufacture. They also have donated a complete engine to be raffled at the Meet.

**DON'T MISS OUT ON THIS ONCE IN A LIFE TIME OPPORTUNITY
A NATIONAL MEET IN YOUR OWN BACK YARD
TOWN & COUNTRY HOTEL**

1928 ERA FASHIONS 1931

JoBeth Stelzer

Need a Shave?

MISTER, YOUR WHISKERS ARE AS waterproof AS MINE!

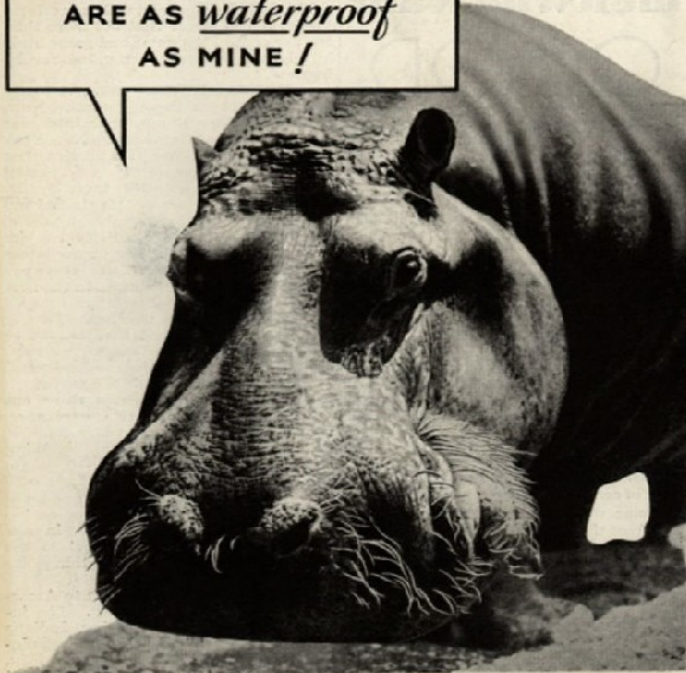

...and that's why shaving is hard for you!

OLD MOTHER NATURE made whiskers waterproof. Made 'em that way by wrapping each whisker in a coating of oil that sheds water like a rubber boot!

And that's why your whiskers stay tough and wiry and hard to cut—until you remove that oil and let the shave cream get to work on the hair itself. But many shave creams aren't much help to you—because they fail to take off *all* the oil.

Colgate's Rapid-Shave Cream is specially made to de-waterproof

whiskers. Colgate chemists have designed it to do *just that*—to strip off every trace of that oil coating... Here's how it works:

Colgate's whips into *small-bubble* lather. Tiny bubbles crowd around each whisker... emulsify the oil... *float it away*. Then—this tiny-bubble lather seeps into each hair... soaks it *soft*... helps the razor cut closely, smoothly. *If you have tough, wiry whiskers, use Colgate's...* and get a smooth, close, lasting shave.

Then... Colgate's After-Shave! Finish your Colgate shave with a dash of Colgate's After-Shave—the lotion that cools and soothes the face. Eliminates stiffness... leaves the skin supple, soft and smooth.

Then for real shaving comfort—add a few pats of Colgate's Talc for Men. Removes that "after-shaving" shine—and it's invisible on the face.



ORDINARY LATHER

This picture (magnified) of ordinary lather, shows how large, air-filled bubbles fail to get close up to the whisker and remove its oily, waterproof coating. Thus the hair remains tough, hard-to-cut.



COLGATE LATHER

This picture of Colgate lather (same magnification) shows how millions of tiny bubbles crowd around each whisker, removing the oily, waterproof coating completely. Thus the hair is softened, easy-to-cut.



Colgate's is made for **WATERPROOF** whiskers

NOTHING softens whiskers like common, ordinary water. But you could douse your face in a tub of water... and *still* have dry, tough whiskers. Here's why...

Every whisker you own is surrounded by an oily, waterproof coating. Many shaving creams fail to *completely* remove this coating, leaving your whiskers dry, *tough*.

Colgate's Rapid-Shave Cream is made to *completely* de-waterproof whiskers! Its rich, *concentrated* lather swarms around every hair. Emulsifies the oily, water-resisting coating... *floats it away*.

Then, tiny water-laden bubbles drench each whisker... soften it... make it a cinch for your razor. Try it yourself.

De-waterproof your whiskers with Colgate's... and get a slicker shave!

A boon to your skin!

Colgate's cool, creamy lather is like a balm to touchy skins!

Start your first Colgate shave tomorrow morning. Follow that shave with Colgate's After-Shaving Lotion. Then a pat of Colgate's Talc for men... and you've got a face that feels like smiling!



COLGATE'S, Dept. 324, P. O. Box 81
Hudson Terminal Station, New York City.
Rush me that trial tube of Colgate's Rapid-Shave Cream. I am enclosing 4c to cover mailing costs.
Name _____
Street _____
City _____ State _____

Some of the mens shaving products available were Palmolive, Barbasol, Colgate and who can forget Burma Shave.

Every Shaver
Now can snore
Six more minutes
Than before
By using
Burma Shave



RESTORATION GUIDELINES including REVISION 3

The revisions to the Model A Restoration Guidelines & Judging Standards are being printed and will be available the end of April. By placing one order from our Club, shipped to one address, there will be no shipping charge.

If you already have the Restoration Guidelines & Judging Standards from an earlier printing, you need only purchase the new Revision 3 at a cost of \$13.50 to bring your current manual up-to-date. This revision will include 178 pages with over 150 new photographs and illustrations. There are 16 areas revised with additional technical data.

If you don't already have a copy of the Restoration Guidelines & Judging Standards, you should purchase a complete manual (includes the new Revision 3) in 3-ring binder with index tabs for \$25.00. This complete manual contains over 270 pages of reference information with over 800 illustrations and photos.

The Model A Restoration Guidelines & Judging Standards manual is a "MUST" for every Model A owner's library. **It's not just for restorers but for "DRIVERS" too.**

I will be placing our order on April 11, after the April Club meeting. Please bring your check made out to Arlyn Bieber (either \$13.50 or \$25.00) to the March or April meeting, then pick up your order at the May Club meeting.

Gene Amy found these article in recent issues of the Harbor Lights newsletters. He ask that we share these Tech. Tips with the San Diego membership:

From the 'Model A Judging Standards and Restoration Guidelines', Page 3-3: Hoses and Clamps.

.....Original clamps were either zinc or cadmium plated and were not stamped with size numbers. The clamps were generally installed as follows:

The upper clamps both had the screw on the top side of the hose with the head toward the driver's side. The lower clamp nearest the radiator had the screws on the outside of the hose with the heads facing upward. The clamps at the inlet casting had the screws on the top of the hose with the heads toward the driver's side.



Tech Tip

Submitted by Ted Kuchta

Removal of front spring perches

The front spring perches mounted in the front axle can be a very stubborn part to remove and a method that works very well is to make a press using some Model A parts. It involves using the two front spring U bolts (part # A5-455B) and the front spring center lower plate (part # A5-458). Remove the nut that fastens the perch in place. Place a U bolt on the axle on each side of the front wishbone and position the dimple in the spring plate over the threaded part of the spring perch. The U bolt must have good threads because this will require a lot of force and rusted or pitted threads will strip easily before the perch budges from its resting place. Non castle type nuts are recommended because they provide more thread coverage and load bearing ability. Tighten the four nuts on the U bolts uniformly. This applies pressure to push the perch out of the axle. If this does not move the perch, heat may be needed to help loosen the bond of rust. This procedure works well even when the front axle is still on the car.

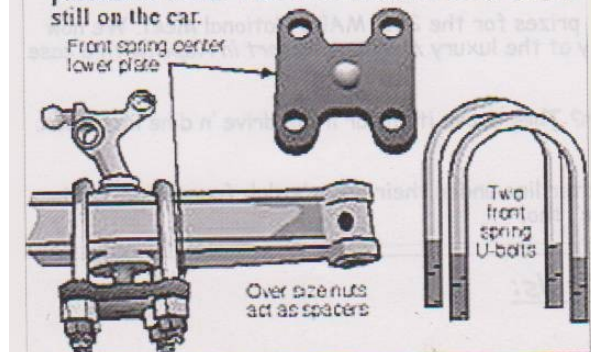



1930-31 Splash aprons (new) \$125.00
 Jimm Kiklis (619) 670-1556

1929 Tudor Sedan. Complete except glass & floor pans. New wood (some), good metal body & fenders asking \$5,800.00. Bonita area
 Chuck Hamilton (619) 701-2047

My Dad passed away 2 years ago and it's time to part with his Model A. We put it in the Restorer Club of America magazine but I live in San Diego and would like it to stay in San Diego if possible. I am asking \$18,000.00 and want someone to appreciate it the way my Dad did.
 My name is Melinda Shumway-Huey, 858-483-5323, or Email me @ huey3inpb@san.rr.com.

L  KING FOR:

1930/31 headlights. Jeff Ott (619) 890-3845

Welcome New Members

James & Jerriann Taber 619-447-7801
 1351 Gibson Highlands
 El Cajon, CA 92021
 They have a '28 Ragtop Pick up.

Greg & Cheri Payne 858-748-5446
 13862 Temple St
 Poway, CA 92064
 They have a '29 Coupe

And returning members
 Dan & Patti Elkerton 619-561-4322
 P.O. Box 481
 Alpine, CA 91903
 They have a closed '29 cab pickup, '29 coupe, and a '29 Fordor leatherback Sedan

Please add all of these new members to your new 2011 roster. Rosters are still available the first one is free and additional copies can be purchased for \$1.00 at the next meeting. See Valarie Basham

REFRESHMENTS: Lisa Kelly



These members are signed up to bring goodies to the March 11th meeting:

- | | |
|-------------------|--------------|
| Gene Amy | Ed Woodruff |
| Joan Minnick | Tom Ace |
| Judy Jo Beardslee | Rich Stelzer |
| Billie Bonnoront | |

March Birthdays

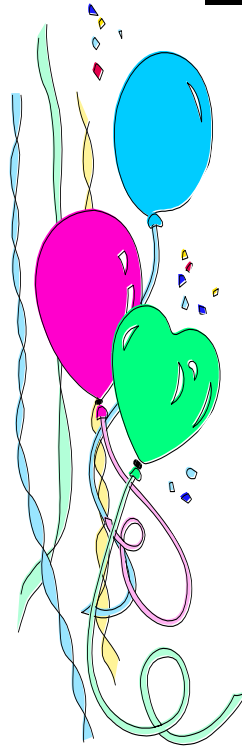

- 1 Richard Potts
- 3 John Watt
- 5 Patty Winchester
- 6 John Frazee
- 7 Irvin Thrush
- 8 Larry Withem
- 9 Neal Melden
- 10 Jane Wehrle
- 17 Barbara Miller
- 18 Ron Peterson
- 20 Gerry Hill
Shirley Thrush
- 21 Ginny Ludtke
- 26 Jim Croff
- 27 Lorrie Ball
- 29 Ric Bonnoront
Kimberly Giery
- 30 Burnette Hill
Sue Winnett
- 31 Dan Seeman

March Anniversaries

- Roger & Eleanore Phillips March 17, 1945
- Neal & Lea Melden March 6, 1960
- Wayne & Pamela Lollis
March 19, 1960
- John & Dianne Frazee
March 26, 1961
- Tom & Janet Westrup
March 29, 1969
- Larry & Bettie Withem
March 8, 1981



Bill Hansen's

Model A Ford Service & Repair
Proudly using KR Wilson Tools for
Dealership Quality



14755 Mussey Grade Rd Day 760-789-8296
Ramona, Ca. 92065 Evenings 619-461-1001 E-
mail lamesla@yahoo.com

Complete Rebuilding of: Engine, Transmission,
Clutch, Rear end, Front End, Steering Box & Brakes.
Other Services: Wheel Balancing, Counter Bal-
anced Crank Shafts, Engine Babbitting, Lightened
Fly-wheels, V8 Clutches, Leakless Water Pumps,
Carburetors, Distributors, Generators, Starters and
more.

CALL FOR COMPLETE LIST OF SERVICES!

"The best place in town to take a leak"

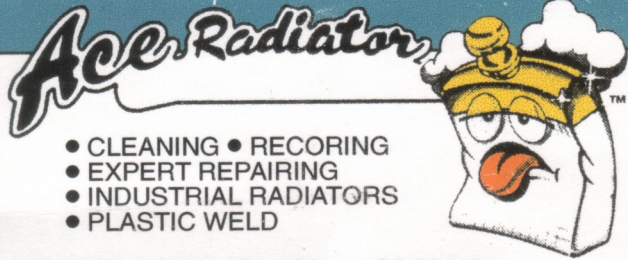

- CLEANING • RECORING
- EXPERT REPAIRING
- INDUSTRIAL RADIATORS
- PLASTIC WELD

1836 National Ave., San Diego, CA 92113

Chaney Silva (619) 233-8811



Mad Jack's
Jack Simmons
1031 Park Ave.
Temet, CA 92544
619-997-3013

mad-jack@juno.com

ABBAY PARTY RENTS

"Your *Discount* Party Supply Warehouse"

Ross Henderson

Tel. 619-599-1025 • Fax 619-599-1029
1027 N. Marshall Ave., El Cajon, CA 92020

S
U
P
P
O
R
T
O
U
R
A
D
V
E
R
T
I
S
E
R
S

Body Paint Mechanical Wood

Webb's Auto Repair & Restoration

Antique & Modern
WEBB H. SMITH

5644 Loping Lane
Bonita, California 92002
619-479-9567



Rich Phillips Auto Service

Complete Auto Repair
Foreign & Domestic

7105-B El Cajon Blvd. Certified Technicians
San Diego, CA 92115 (619) 463-3315

Generators
Starters
Regulators

Batteries

Solenoids
Alternators
Remanufacturing

Broadway Auto Electric

7825 NORTH AVENUE
LEMON GROVE, CALIFORNIA 91945

RICK ZITREN

(619) 461-4555
FAX 461-4899

OLD CARS & PARTS

SINCE 1986



Street Rods or Original

619.449.0551

10011 Prospect Ave. • Santee, CA 92071

Hank

LINES & DESIGNS by Robert Gagnon

Hand Painted Pinstriping

Custom Artwork & More



619-889-8588

www.Ldbyrg.com

ALL ABOARD:

Pacific Southwest Railway February Tour



1928  1931

M.A.R.C./M.A.F.C.A. of San Diego
P.O. BOX 19805
San Diego, Ca. 92159

FIRST CLASS POSTAGE
DATED MATERIAL ENCLOSED
ADDRESS CORRECTION REQUESTED